

A PARTIR DE LA SERIE No. 23,891

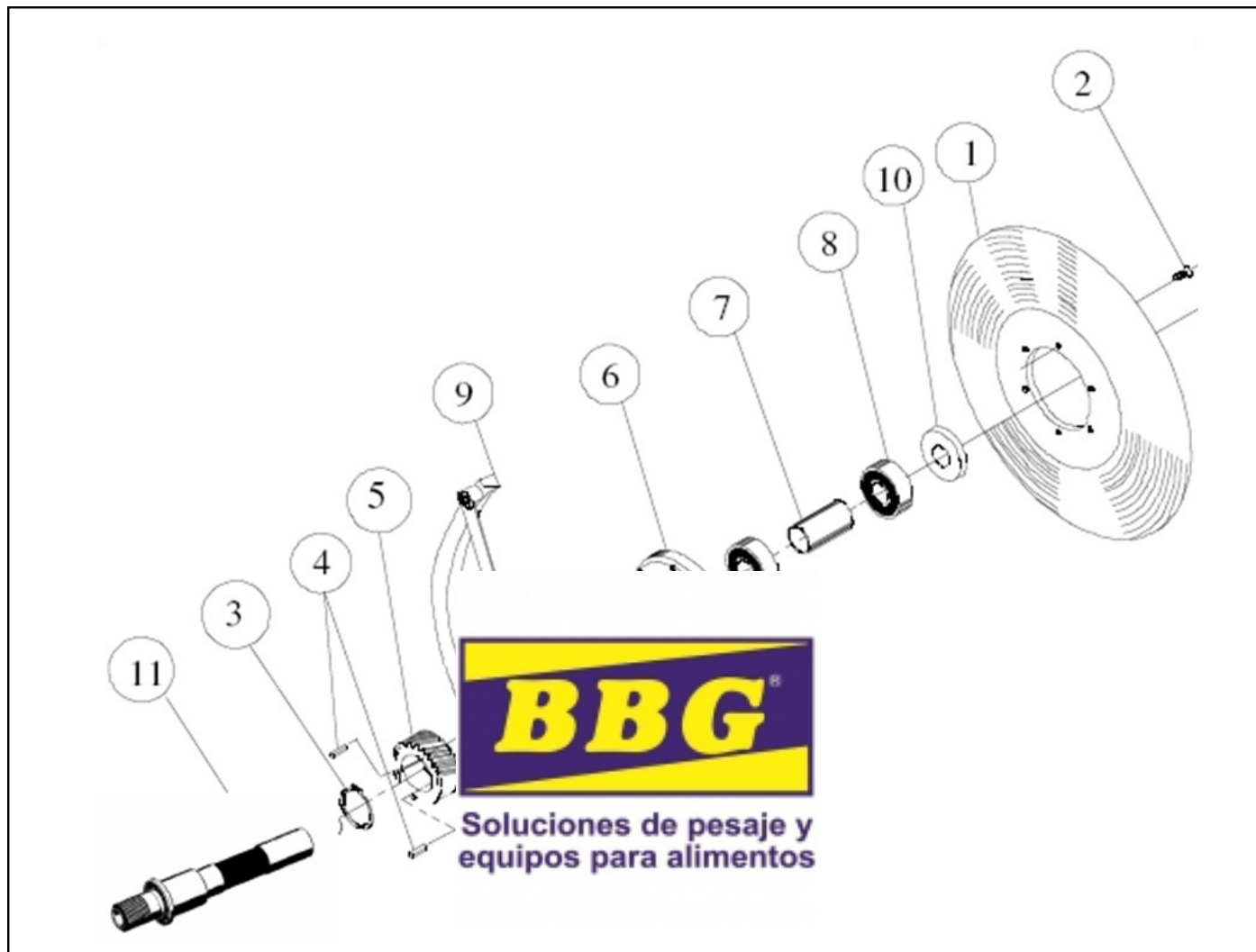

No.	DESCRIPCION	CODIGO	CANT.	I.S./100
1	CUCHILLA SOLIDA 300mm DIA. CROMADA	M500001	1	2
1	CUCHILLA SOLIDA 300mm DIA. A.I.	M501470	1	2
2	TORNILLOS CAB. PLANA #8-32 N.C. x 1/2" A.I.	M501471	6	2
3	CANDADO 5100-137	M500279	1	2
4	CUÑAS DE 1/8" x 1/8" x 5/8"	M570132	2	2
5	CORONA DE NYLAMID	M570400	1	4
6	CAMPANA	M571474	1	2
7	SEPARADOR DE BALEROS	M570247	1	2
8	BALEROS 6204-2RS1	M500184	2	2
9	PROTECTOR DE CUCHILLA SUBENS.	M571671	1	2
*10	RETEN #500272	M502287	1	2
10	RETEN #20477	M501549	1	2
11	FLECHA A.I. P/BALEROS	M572238	2	2

CAMPANA SUB-ENSAMBLE COMP. FIGS. 3 A LA 8 Y 10, 11 M571931

\* A PARTIR DE LA SERIE N° 23,891,CAMBIA MEDIDA DE RETEN.

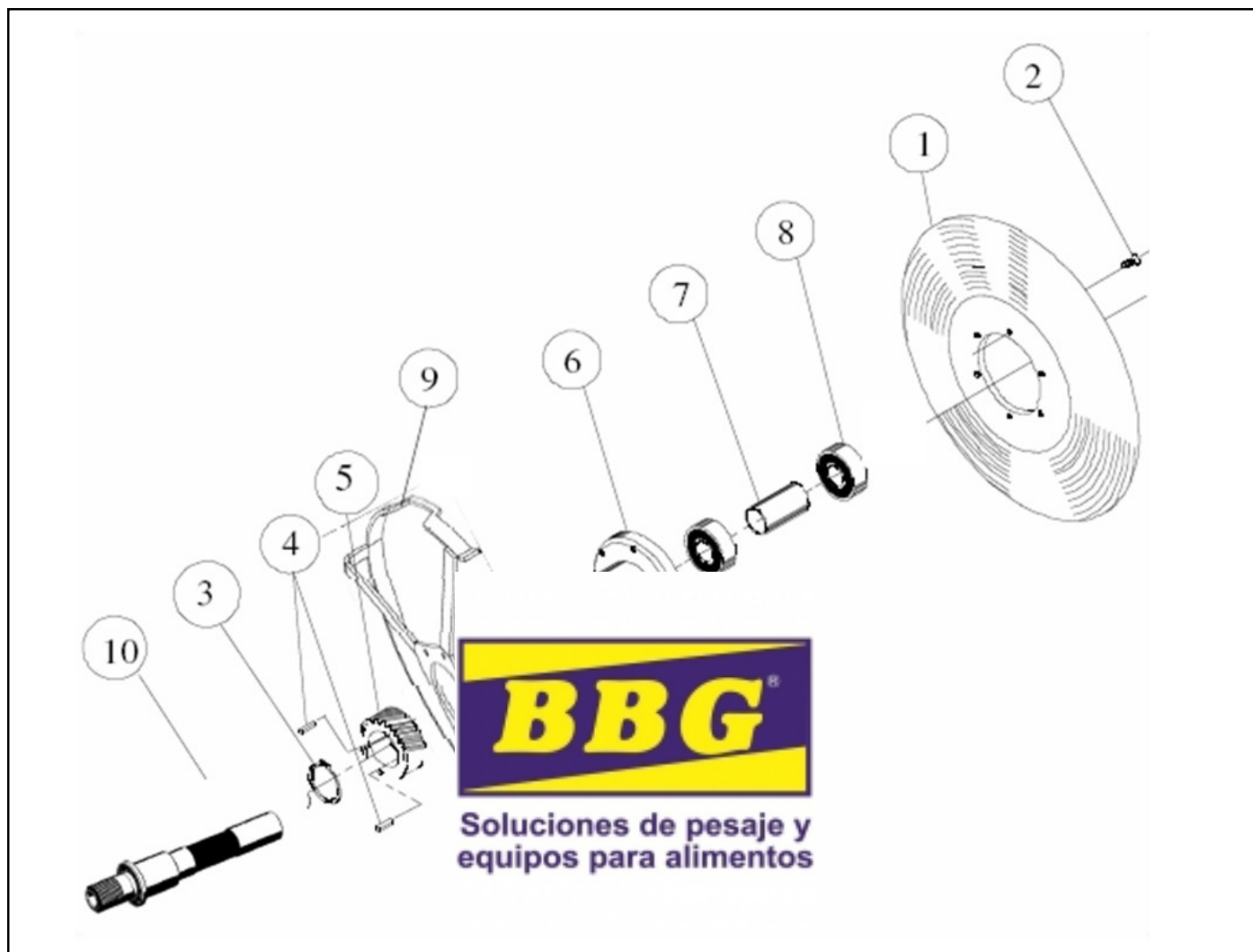

No.	DESCRIPCION	CODIGO	CANT.	I.S./100
1	CUCHILLA SOLIDA 300 MM. DIAM. CROMADA (R	M500001	1	2
1	CUCHILLA SOLIDA 300 MM. DIAM. A.I. (R-30	M501470	1	2
2	TORNILLOS CAB. PLANA #8-32 N.C. x 1/2" A.I.	M501471	6	2
3	CANDADO 5100-137 ( R-300\A )	M500279	1	2
4	CUÑA DE 1/8" X 1/8" X 5/8" ( R-300\A	M570132	2	2
5	CORONA DE NYLAMID (R-300\A)	M570400	1	4
6	CAMPANA (MAQ.) ( R-300\A ) (REF 99)	M571474	1	2
7	SEPARADOR DE BALEROS (R-300\A)	M570247	1	2
8	BALERO #6204-2RS1	M500184	2	2
*9	PROTECTOR DE CUCHILLA SUBENS. ( R-300A )	M571671	1	2
10	FLECHA P/ BALEROS A.I. C/TUERCA ( R-300\	M572238	2	2

CAMPANA SUB-ENSAMBLE COMP. FIGS. 3 A LA 8 Y 10, 11

M571931

\* SE ELIMINA RETEN Y CAMBIA A PROTECTOR DE ACERO INOX.

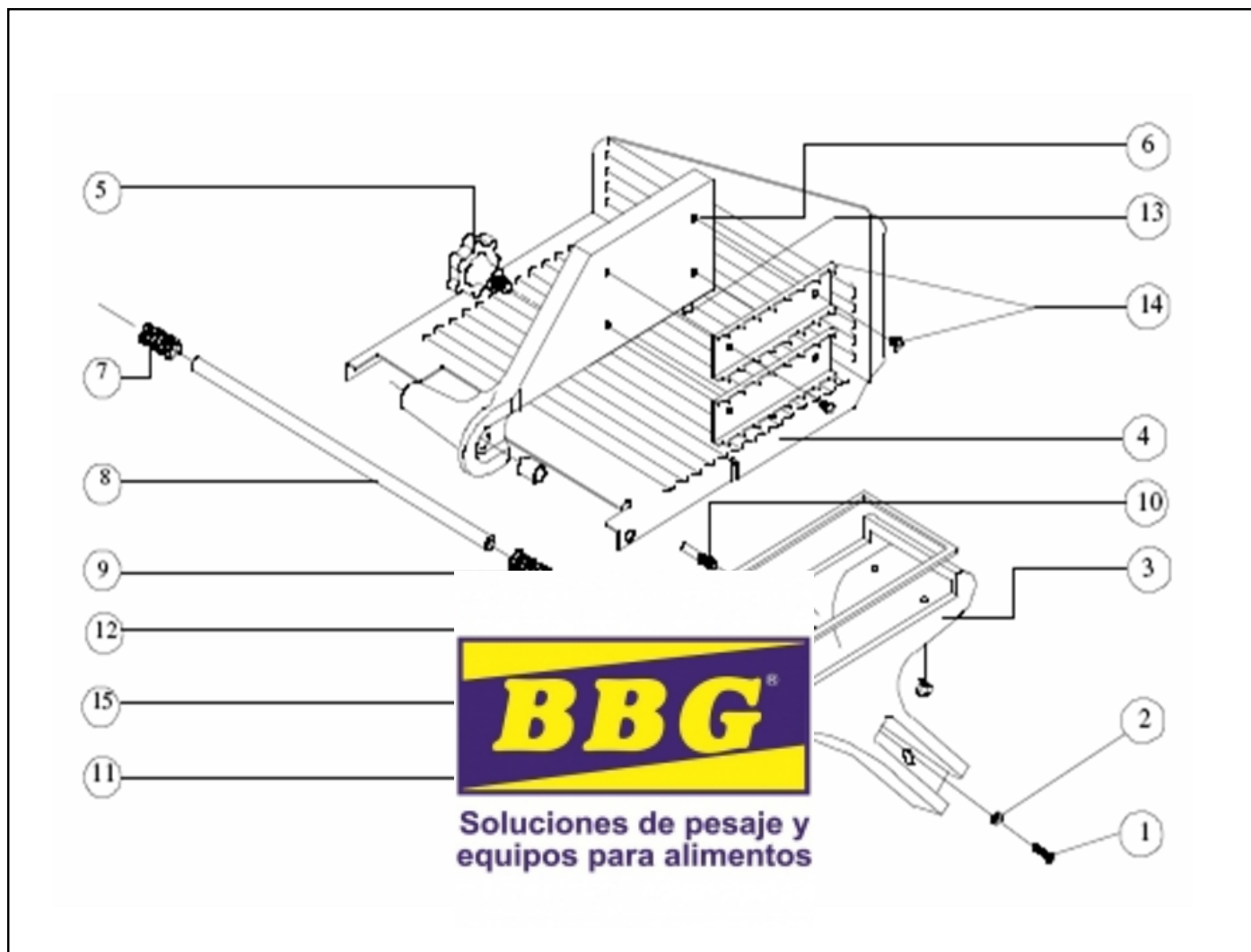

No.	DESCRIPCION	CODIGO	CANT.	I.S./100
1	TORN. CAB. HEX. 1/4" x 1" A.I.	M500662	1	2
2	TUERCA HEX. 1/4" STD	M500303	1	2
3	PORTACARRO	M571417	1	2
4	CARRO SUB-ENSAMBLE ( R-300\A )	M571173	1	2
5	PERILLA ESPAÑOLA P/PISON 3/8" C/TOR AI	M500092	1	2
6	PISON SUBENS. COMP. FIGS. 5, 13, 14 Y 15	M571380	1	2
7	RESORTE P/BARRA DEL PISON A.I. SUP. ( R-	M501550	1	2
8	BARRA DEL PISON ( R-300\A ) (REF 96)	M570184	1	2
9	RESORTE P/BARRA DEL PISON INF.	M501545	1	2
10	PERNO CILINDRICO ROSCADO AI (R-300A)	M570152	1	2
11	TUERCA BELLOTA #8-32 A.I.	M500714	4	2
12	TORNILLOS CAB. PLANA 3/16" x 3/8" A.I.	M501541	2	2
13	TOPE DE NYLON PARA PISON	M500332	1	2
14	PLACAS DE AI DENTADAS C/TORNS	M572230	2	2
15	CINTA P/CARRO-PORTACARRO R-300 0.54m	M571676	1	2
	<b>CARRO COMPLETO SUBENS. R-300 (KIT-REF-96</b>	<b>M571932</b>	<b>1</b>	<b>2</b>

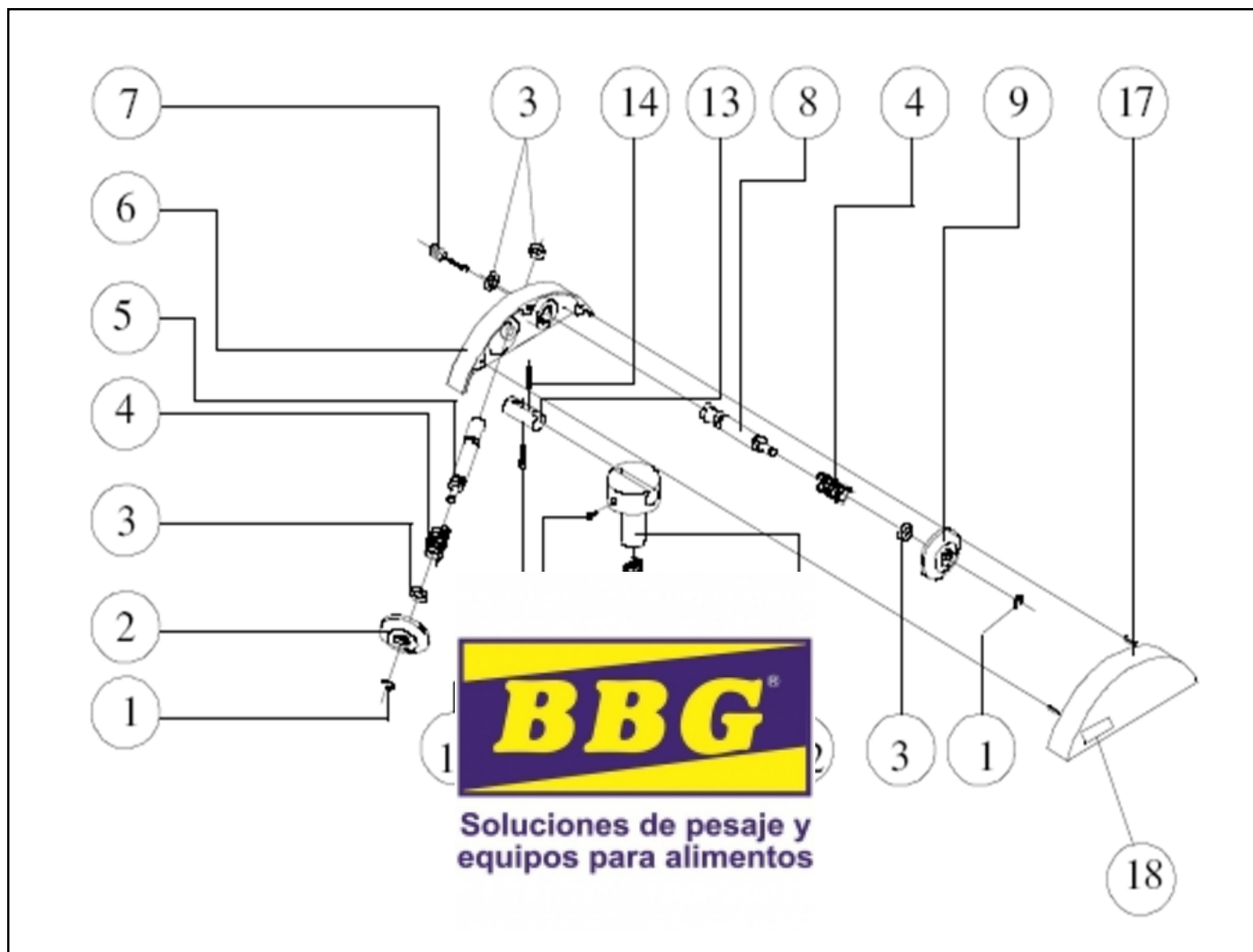

No.	DESCRIPCION	CODIGO	CANT.	I.S./100
1	CANDADOS 5133-31	M500280	2	2
2	PIEDRA DE AFILAR Y BUSHING DE BRONCE SUBENS.	M570542	1	10
3	EMPAQUES O-RING #2-112	M500338	4	2
4	RESORTES PARA FLECHAS DE ACENTAR Y AFILAR A.I.	M501544	2	2
5	FLECHA PARA PIEDRA DE AFILAR	M570136	1	2
*6	BASE DE AFILIDAOR SUBENS.	M571933	1	2
7	PERILLA PARA AFILADOR-TAPA TOR. INOX	M572990	1	2
8	FLECHA PARA PIEDRA DE ACENTAR	M570134	1	2
9	PIEDRA DE ACENTAR Y BUSHING DE BRONCE SUBENS.	M570541	1	10
10	ARO DE AC. INOX.	M533000	1	2
11	RESORTE A.I. PARA MAMELON DE ZAMACK	M501546	1	2
12	MAMELON DE ZAMACK	M570323	1	2
13	CILINDRO DE LATON	M570397	1	2
14	PERNO ROLL PIN 5/32" x 1"	M500271	1	2
15	TORNILLO CAB. SOCKET 3/16" x 1"	M500193	1	2
16	TORNILLO CAB. PLANA 5/32" x 3/8" A.I.	M501540	1	2
*17	TAPA DE AFILADOR	M570721	1	2
18	CALCAMONIA DE "DANGER" DE AFILADOR"	M501260	1	2
	AFILADOR SUBENS. COMP. FIGS. 1 A LA 18	M571934	1	2

\* CAMBIA AFILADOR TIPO CE

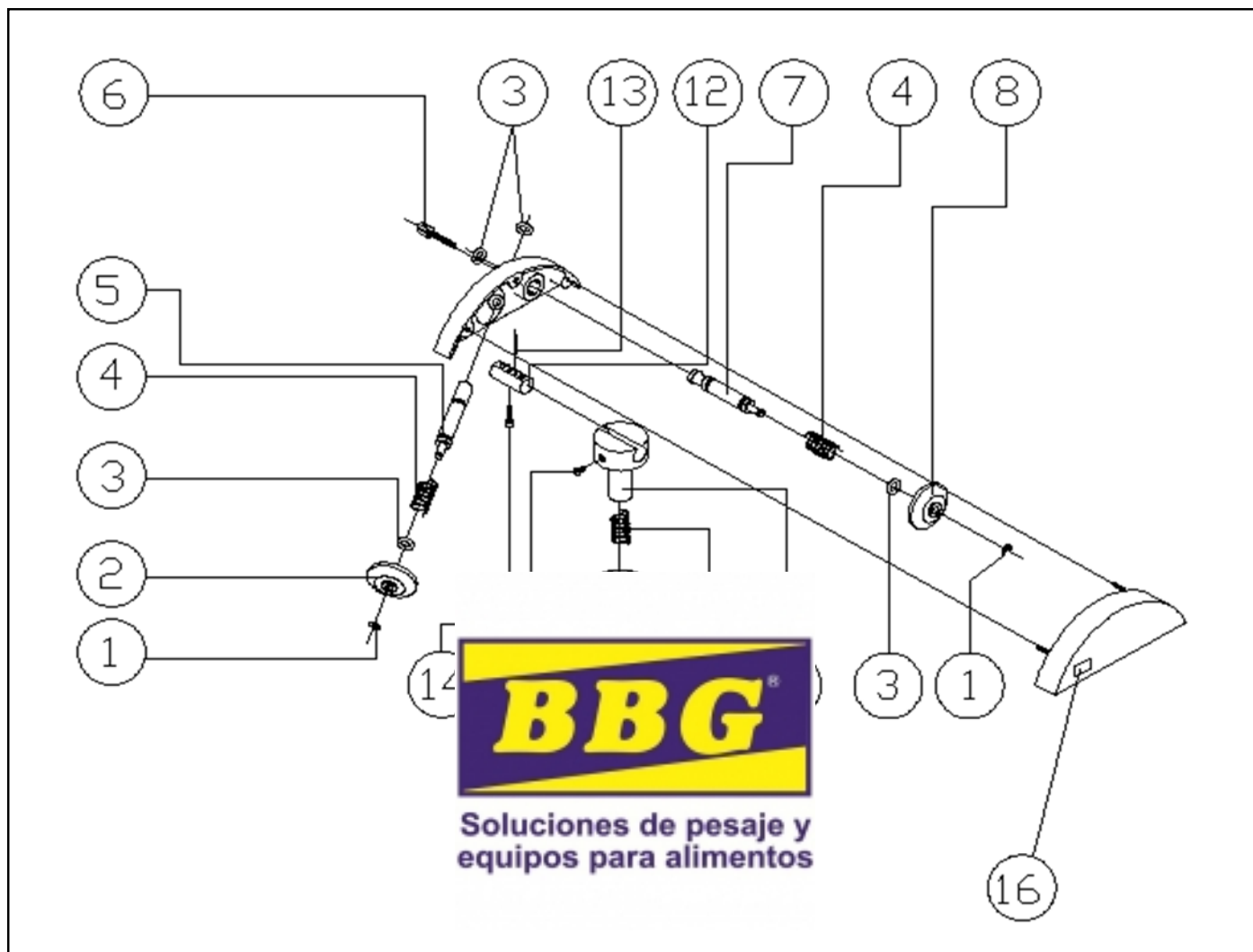

No.	DESCRIPCION	CODIGO	CANT.	I.S./100
1	CANDADO #5133-31	M500280	2	2
2	PIEDRA DE AFILAR Y BUSHING DE BRONCE SUB	M570542	1	10
3	EMPAQUE O-RING #2-112 P-FLECHAS AFILADOR	M500338	4	2
4	RESORTE P/FLECHAS ACENT Y AFIL (GALV) (R	M501544	2	2
5	FLECHA PARA PIEDRA DE AFILAR (R-300\A)	M570136	1	2
6	PERILLA PARA AFILADOR-TAPA ( R-300A ) (R	M572990	1	2
7	FLECHA P/PIEDRA DE ACENTAR ( R-300\A )	M570134	1	2
8	PIEDRA DE ACENTAR Y BUSHING DE BRONCE (R	M570541	1	10
9	ARO DE A.I. P/MAMELON (R-300\A)(REF 96)	M533000	1	2
10	RESORTE P/ MAMELON DE ZAMACK (REF 96)	M501546	1	2
11	MAMELON DE ZAMACK (MAQ.) ( R-300\A )	M570323	1	2
12	CILINDRO DE LATON (R-300\A )	M570398	1	2
13	PERNO ROLL PIN 5/32" X 1" ( R-300\A )	M500271	1	2
14	TORNILLO CAB. SOCKET 3/16" x 1"	M500193	1	2
15	TORNILLO CAB. PLANA 5/32" x 3/8" A.I.	M501540	1	2
16	CALCOMANIA DE "DANGER" DE AFILADOR"	M501260	1	2
AFILADOR SUBENS. COMPLETO (R-300)		M571934	1	2



DE LA SERIE 23,891

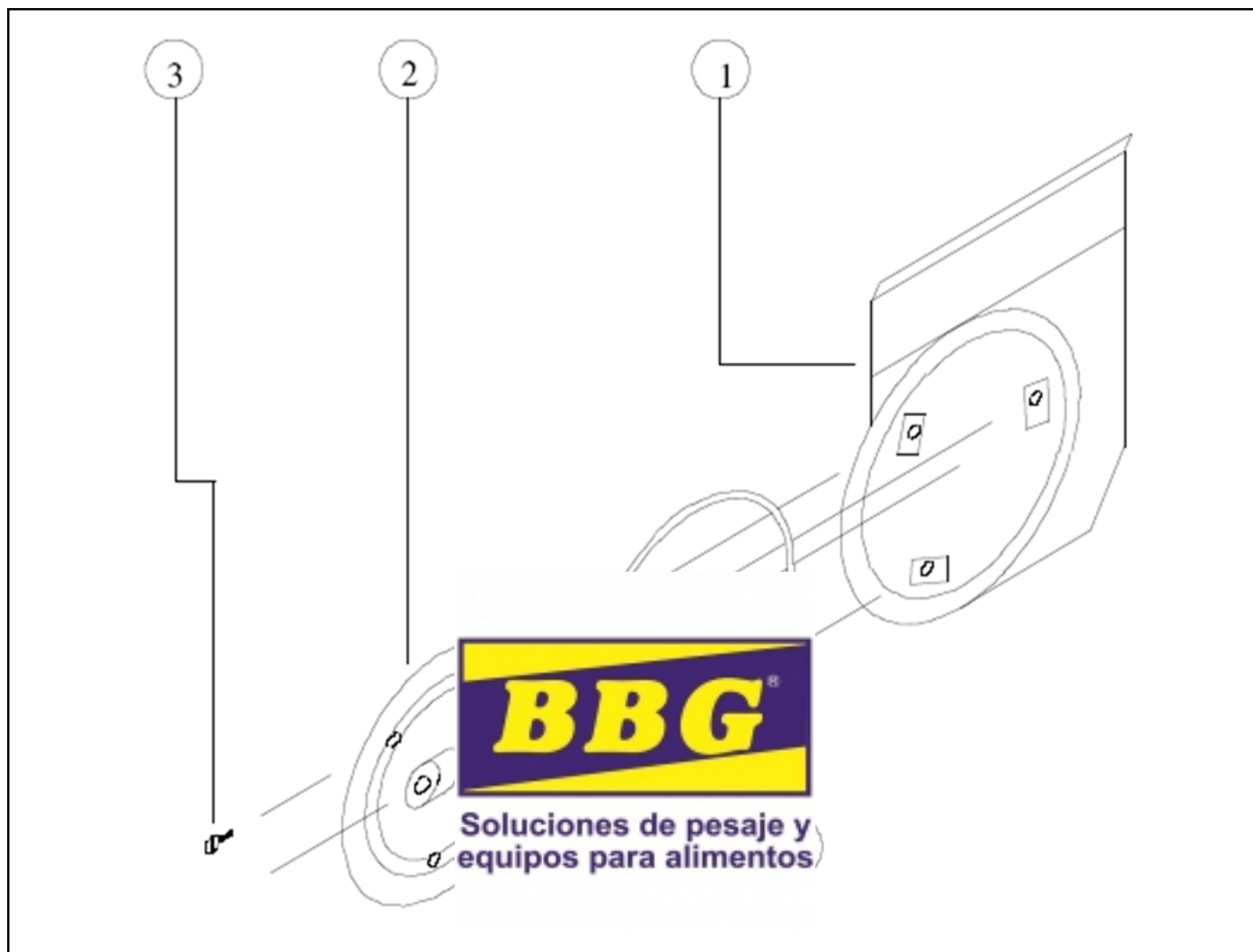

No.	DESCRIPCION	CODIGO	CANT.	I.S./100
1	PLANCHA P/PLATO	M570473	1	2
2	* PLATO	M571425	1	2
3	TORNOS. CAB. PLANA 3/16" x 3/8" A.I.	M501541	3	2
4	CINTA PARA PLATO-PLANCHA P/PLATO 0.63m	M571677	1	2
	PLATO SUBENS. COMP. FIGS. 1,2,3 Y 4	M571935	1	2

\* A PARTIR DE LA SERIE No. 23,891, CAMBIA PLATO



DE LA SERIE: C05-039403



No.	DESCRIPCION	CODIGO	CANT.	I.S./100
1	PLANCHA P/PLATO ( R-300\A )	M570473	1	2
2	* PÓRTAPLATO	M570915	1	2
	PLATO SUBENS. COMP. FIGS. 1,2,3 Y 4	M571935	1	2

\* A PARTIR DE LA SERIE CM5039403, SE REDISEÑO PLATO (SE AGREGARON TORNILLOS AUTOSOLDABLES)



DE LA SERIE: #2122



No.	DESCRIPCION	CODIGO	CANT.	I.S./100
1	TUERCA BELLOTA #8-32 UN	M500714	7	14
2	TORNILLO A.I. 1/2" x 1 1/2" MAQUINADO	M574198	1	2
*3	ARANDELA PARA PORTA PLANCHA	M574233	1	2
*4	PORTA PLANCHA DEL REGULADOR CON ESFERICO	M571418	1	2
*5	PLANCHA DEL REGULADOR CON TORNOS. AUTOSOLDABLES	M571174	1	2
*6	OPRESOR DE 1/4 x 1/2 STD	M500246	1	2
*7	CINTA P/PLANCHA-PORTAPLANCHA 0.72m	M571675	1	2
*8	SEPARADOR ESFERICO P/PLANCHA (R-300A)	M573405	1	2
	PLANCHA REGULADORA SUB-ENSAMBLE COMP. FIGS. 1 a 8	M571936	1	2

\* A PARTIR DE LA SERIE No. 2122, SE AGREGA ESFERICO Y TORNILLOS AUTOSOLDABLES.



DE LA SERIE: 22,837

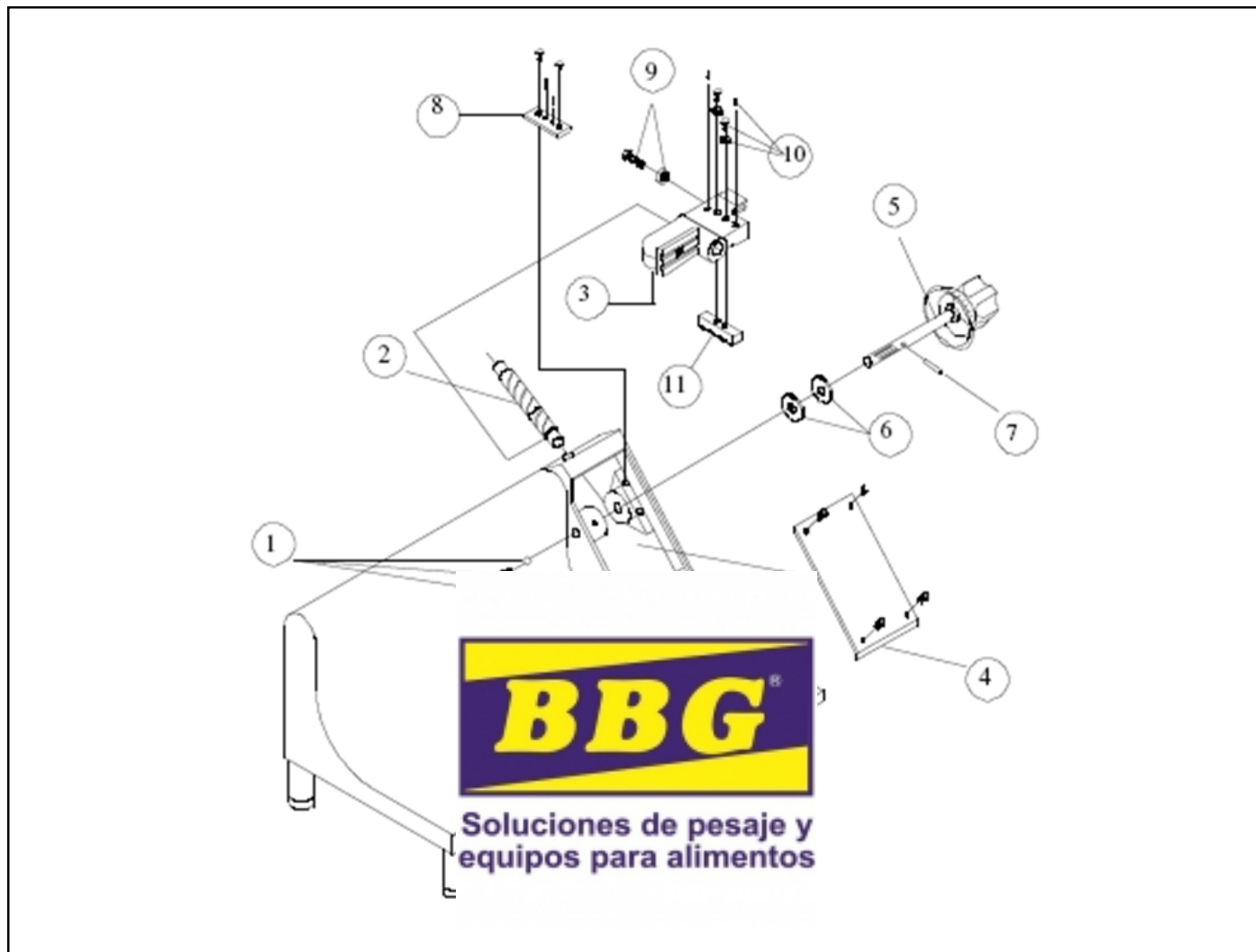

No.	DESCRIPCION	CODIGO	CANT.	I.S./100
1	TORNILLO REG. DE PRESION C/POSTA Y RESOR	M571919	1	2
2	PERNO GUIA DEL REGULADOR ( R-300\A )	M570156	2	2
3	REGULADOR ( R-300 )	M571423	1	2
4	TAPA DE MECANISMO REGULADOR ( R-300A )	M571937	1	2
*5	PERILLA REGULADORA DE CORTE ( R-300 )	M502208	1	2
*6	ARANDELA DE NYLON P/PER. REG. ( RB-250\3	M501249	2	4
*7	PERNO ROLL PIN 3/16 X 3/4 (R-300A)	M500275	1	2
8	PLACA NIVELADORA C/TORNS. Y OPRESORES (	M572232	1	2
9	TORN. CAB. HEX. 5/16" x 3/4" Y TUERCA (NO REFACCION)			
10	TORNS.ARANDS. Y OPRESORES DE 1/4"(JUEGO)(NO REF.)	M572234	2	2
11	CREMALLERA ( R-300\A )	M570131	1	2

REGULADOR COMPLETO R-300A

M572235

\* A PARTIR DE LA SERIE No. 18,837, CAMBIA DISEÑO DE PERILLA REGULADORA

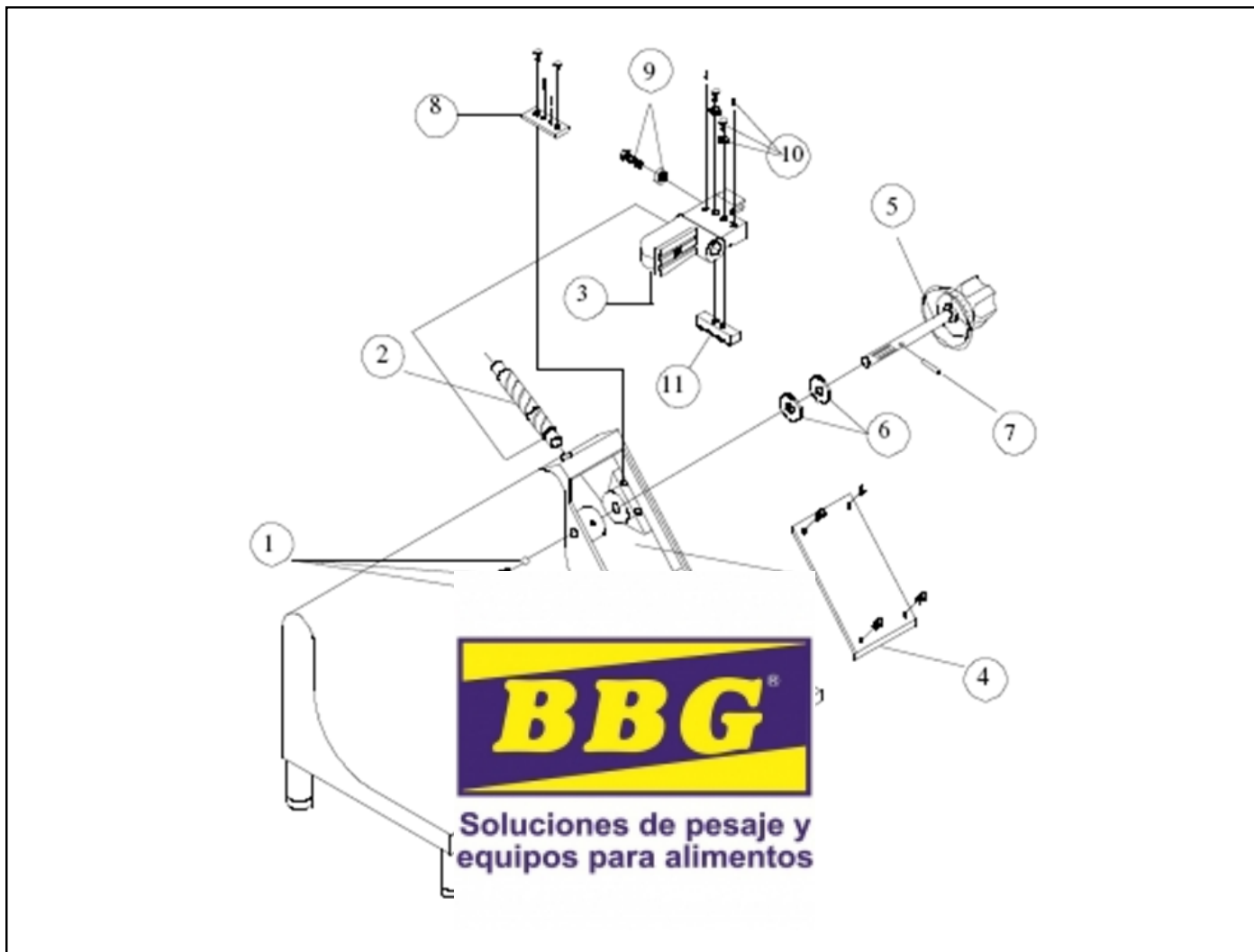

No.	DESCRIPCION	CODIGO	CANT.	I.S./100
1	TORNILLO REG. DE PRESION C/POSTA Y RESOR	M571919	1	2
4	TAPA DE MECANISMO REGULADOR ( R-300A )	M571937	1	2
5	PERILLA REGULADORA DE CORTE ( R-300 )	M502208	1	2
6	ARANDELA DE NYLON P/PER. REG. ( RB-250\3	M501249	2	4
7	PERNO ROLL PIN 3/16 X 3/4 (R-300A)	M500275	1	2
8	PLACA NIVELADORA C/TORNS. Y OPRESORES (	M572232	1	2

\*REGULADOR COMPLETO R-300A

M572235

\* SE AGREGA KIT REGULADOR

DE LA SERIE: 25,933

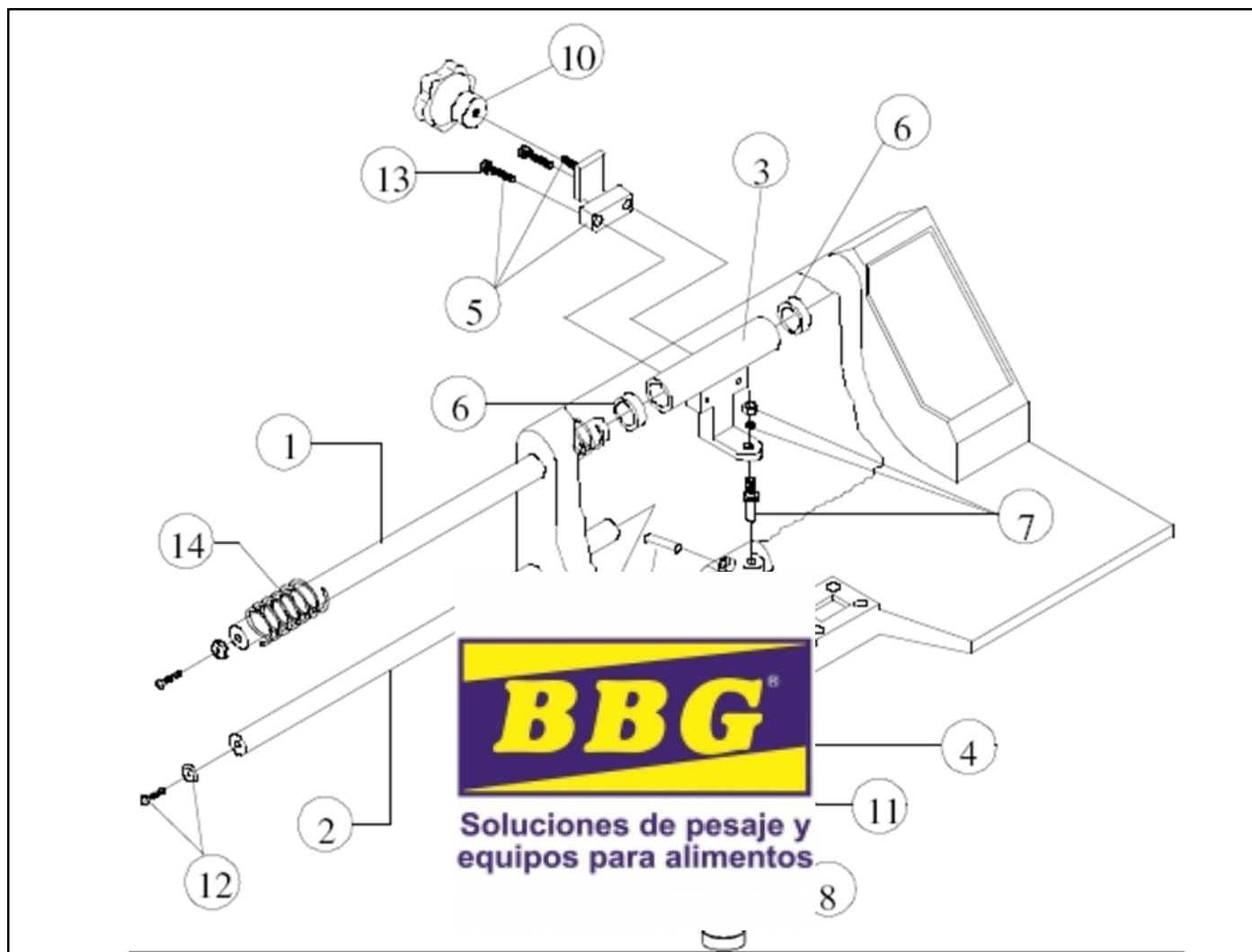

No.	DESCRIPCION	CODIGO	CANT.	I.S./100
1	BARRA SUP. 1" DIAM. C/ARAND. DE FORMA	M571921	1	2
2	BARRA INF.7/8"C/ARAN.DE FORMA Y TORNOS.	M571922	1	2
3	BUJE LARGO SUPERIOR ( R-300\A )	M570344	1	2
4	BUJE CORTO INFERIOR ( R-300\A )	M570341	1	2
5	SOPORTE P/PORTACARRO C/TORNOS. ( R-300A )	M571923	1	2
6	TOPE DE HULE P/BARRA (R-300A)	M500336	2	2
7	EXCENTRICO DE BARRAS C/TUERCA Y ARAN. (	M571924	1	2
*8	PATA INYECTADA PARA R-300	M503465	4	2
9	TUBO LUBRICADOR ( R-300A )	M570552	1	2
10	PERILLA P/PORTACARRO (R-300) REF	M506930	1	2
*11	TUBO DE ALUMNIO P/PATA INYECTADA R-300	M574769	4	2
12	TORNILLOS Y ARAND.DE FORMA 1/4"(KIT RE	M572236	4	2
13	TORNOS. CAB. SOCKET 1/4" x 1" A.I.	M501542	2	2
14	RESORTE P/BARRA DE BUJE LARGO R-300A	M501543	2	2

\* A PARTIR DE LA SERIE No. 25,933, CAMBIA MODELO DE PATA.

DE LA SERIE: 19,050 Y 19,144

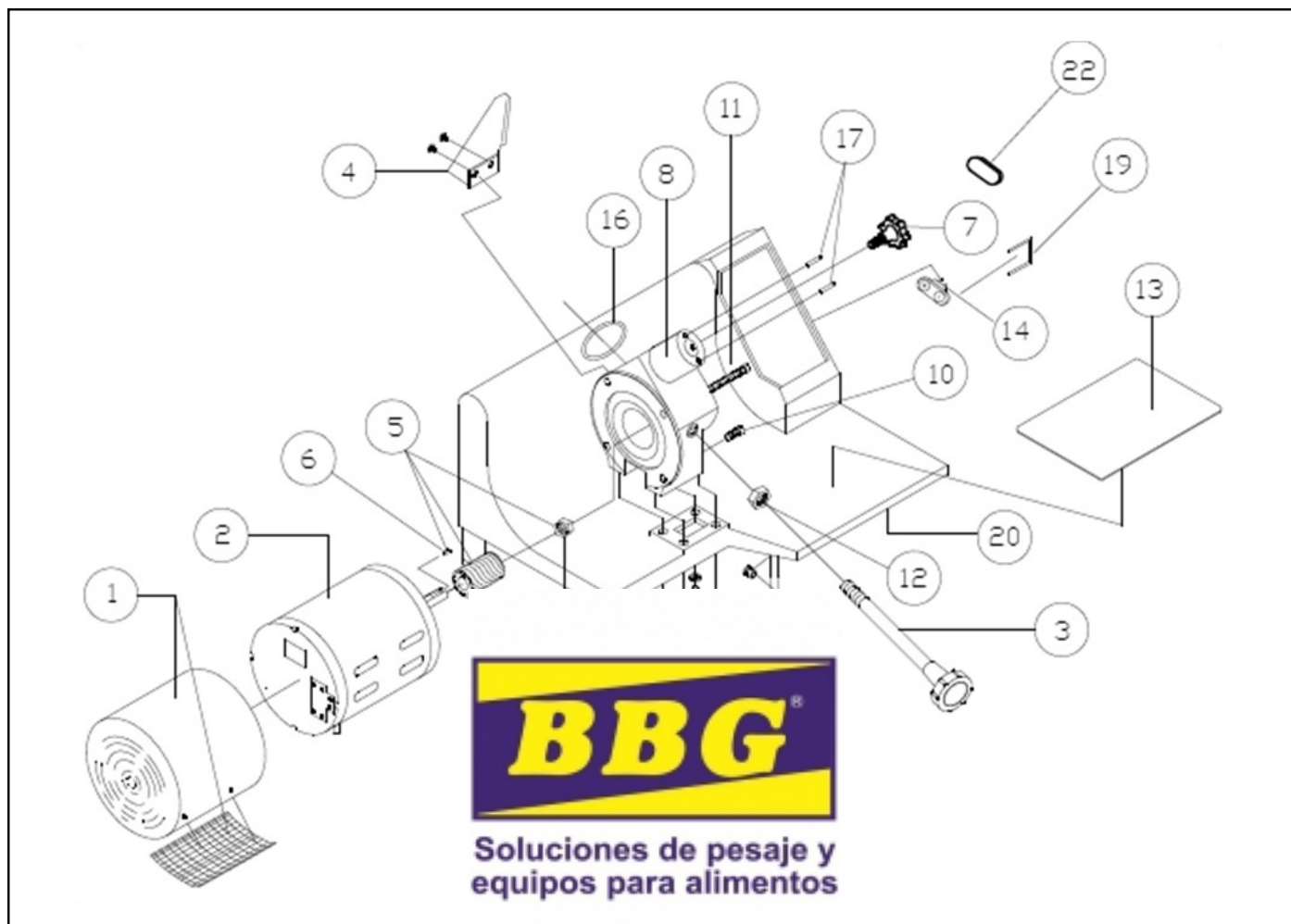

No.	DESCRIPCION	CODIGO	CANT.	I.S./100
*1	CUBREMOTOR C/ MALLA SUBENS R-300 (MAQ.)	M573213	1	2
2	MOTOR 1/3 C.P. MONOFASICO 50Hz.	M501309	1	2
2	MOTOR 1/3 C.P. MONOFASICO 60Hz.	M500176	1	2
3	PERILLA P/PLATO R-300 C/VARILLA A.I.	M532908	1	2
4	DESVIADOR C/TORNILLOS A.I. ( R-300A )	M571925	1	2
5	SINFIN DE 6 ENTRADAS C/CUÑA Y TUERCA ( R	M572239	1	4
6	CUÑA WOODRUD #404-3 (1/8 X 1/2")	M500295	1	2
7	PERILLA P/SUJETAR AFILADOR (TOR.INOX) R-	M570778	1	2
8	CAJA DE TRANSMISION COMP. FIGS. 18, 19 Y	M571938	1	2
9	TUERCA HEX. 7/16" - NF	M500308	1	2
10	TORN. CAB. GOTA 3/8" X 3/4" CROMADO R-	M570411	2	2
11	TORNS. 3/8" X 3 1/4" (CROMADOS) ( R-3	M570409	2	2
12	CONTRATUERCA HEX. 3/4" P/FLECHA (50218	M570419	1	2
13	PLACA RECIBIDORA ( R-300A )	M571306	1	2
14	INTERRUPTOR 0401/TTR RED B142/GREEN B143	M503481	1	2
15	CABLE TOMA-CORRIENTE #1331 UL C/CLAVIJA	M500155	1	2
16	FIELTRO ( R-300\A )	M570551	1	2
17	PERNO SOLIDO 3/16 X 1 1/2 AC INOX T-304	M501316	2	2
18	TORNS., PERNOS Y ARANS. P/SUJETAR CAJA (JUEGO)	M572820	1	2
*19	CANDADO PARA INTERRUPTOR	M501571	1	2
20	SERCHA DE A.I.CAL.22 12 9/6"x3"R-300A	M573007	1	2
21	GROMMET MP7P-2 (3x14 SJT)	M500799	1	2
22	CAPUCHON PARA INTERRUPTOR 0401/TTR	M503545	1	2
	KIT DE MOTOR 50Hz R-300\A	M571038	1	2
	KIT DE MOTOR 60Hz R-300\A	M571927	1	2

\* A APARTIR DE LA SERIE No. 19,050, CAMBIA CANDADO P/ INTERRUPTOR, Y

\* A PARTIR DE LA SERIE No.19,144, CAMBIA MODELO DE CUBREMOETOR.